

PARKSIDE



PWS 1100

CE 2002





Operating instructions

Page

4 - 7



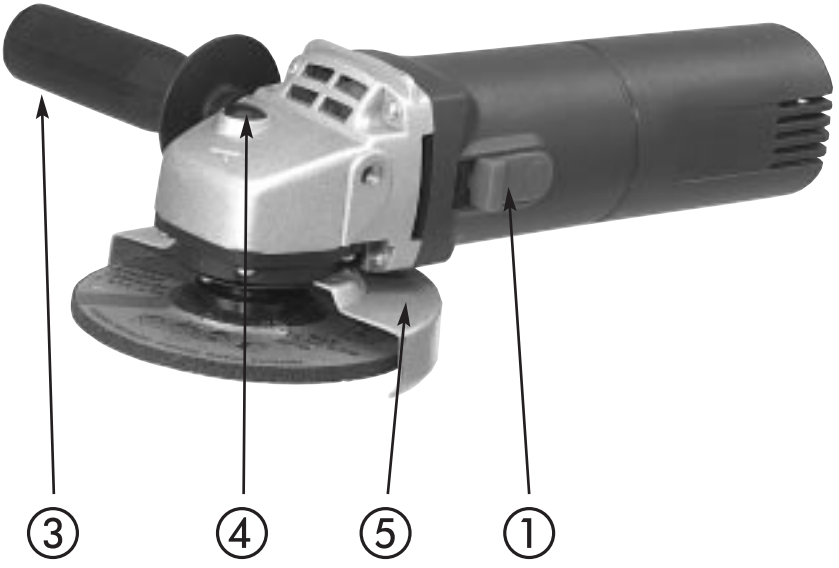

1

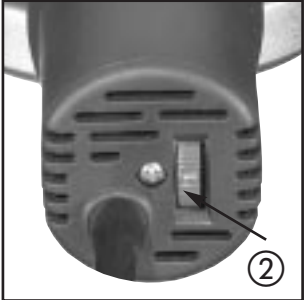

2

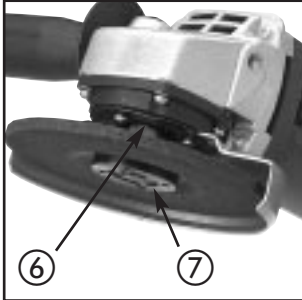

3





PARKSIDE

PARKSIDE

PWS 1100 ANGLE GRINDER

For grinding, roughing, cutting and polishing

Dear Customer! Please make sure you familiarise yourself fully with the way the equipment works before you use it for the first time and that you understand how to handle electrical power tools correctly. Please read the operating instructions  below and the accompanying safety advice  carefully. Use the equipment only as described and for the indicated purposes. By doing this you will be able to work in complete safety and produce better results.

FEATURES OF THE PARKSIDE PWS 1100

- ① ON / OFF switch
- ② Speed control wheel (Fig. ①)
- ③ Auxiliary handle
- ④ Spindle lock
- ⑤ Adjustable safety guard
- ⑥ Clamping flange (Fig. ②)
- ⑦ Clamping nut (Fig. ②)
- ⑧ Wrench (not illustrated)

TECHNICAL INFORMATION

Nominal power:	1100 W
Nominal voltage:	230 V ~ 50 Hz
Low load speed:	n_0 3,000 – 11,000 /min
Spindle:	14 mm
Grinding disc:	125 x 22 x 6 mm (outside diameter x hole size x thickness)
Sound pressure level:	91.2 dB(A) (to EN 50144)
Sound power level:	104.2 dB(A) (to EN 50144)
Vibration:	< 2.5 m/s ² (to EN 50144)
Protection class:	II
Weight:	2.4 kg



The PWS 1100 angle grinder has INTELLIGENT POWER CONTROL. This electronic management system monitors and controls your angle grinder in its various operating states;

Operating state

Feature

Switching On:	The IPC electronic system start-up mode ensures that the motor starts up slowly and gently. This largely avoids heavy transient current surges, and means that electrical safety cut-out devices are not generally tripped (building sites, domestic premises).
No-load running:	After switching on, the IPC electronic system run-up mode takes the grinder's speed up to the pre-set required value (Setting 1 ... 6). After this is reached, the IPC system speed control mode keeps the grinder operating at a constant speed.
Load / overload operation:	The IPC electronic system mode sees to it that, when working under load, the grinder cannot inadvertently become overloaded. If the grinder's nominal performance rating is reached or exceeded during use, the IPC electronic system signals to you with additional power pulses that there is an overload. These power pulses become more pronounced with increasing overload.

PARKSIDE

If the overloading of the grinder is increased further in spite of these warnings, the IPC electronic system activates an integrated current limiter, which restricts the overloading of the power tool by setting a maximum operating current of 11 A. This prevents the tool from burning out and being destroyed.

The IPC electronic management system has several modes of operation. These modes are designed to get the best out of the grinder and allow you to work in a safe and efficient manner. Heavy transient current surges and the resulting tiresome tripping of safety cut-out devices are largely avoided. The speed controller ensures a relatively low constant no-load speed and with this a long operating life for your grinder. By making these quick re-adjustments, the IPC electronic management system ensures - even during the work and under rapidly changing load conditions - that you always have the perfect grinder performance at your disposal. The overload control constantly checks and monitors the output of the tool during the work. It warns you in the event of overload and limits the overloading of the grinder to a maximum value.

IMPORTANT SAFETY ADVICE ⚠

- To be read in conjunction with the advice in the accompanying booklet on safety.
- Only use certified fibre reinforced cutting discs or fibre reinforced depressed centre grinding discs that have a permissible circumferential speed of not less than 80 m/s.
- Check that the speed stated on the grinding disc is greater than or equal to the grinder's nominal speed.
- Make sure that the size of the disc is suitable for use with the angle grinder and that the disc fits correctly on to the clamping flange ⑥.
- Look after your health: Wear ear defenders - also wear safety glasses and a breathing/dust mask.
- The angle grinder is only to be used for dry cutting / grinding.
- Do not use on materials containing asbestos.
- Only place the grinder into contact with workpiece once it has been switched on.
- Note the direction of rotation and always hold the angle grinder so that the sparks and grinding debris are thrown away from your body.
- Always check carefully that workpiece is correctly mounted and securely held.
- Do not use the sides of cutting discs for grinding.
- Take note that working on stone and wood can give rise to dusts that can damage your health.
- Take note that working on metals can give rise to flying sparks. Make sure that nobody is placed in danger and that due to the risk of fire there are no inflammable materials nearby.
- Caution. — The angle grinder continues to rotate after it has been switched off. Do not press the sides against anything to slow it down more quickly.
- Always keep the power cable well out of the grinder's working area and fed to the rear of the machine.

OPERATION

1. Take note of the mains voltage. The voltage must agree with that shown on the identification plate (equipment shown as 230 V can also be used with 220 V).
2. Check the grinding disc. It should not be damaged, wet or cracked. As a safety measure, run the angle grinder for about 30 seconds under no load. Look out for any unusual noises or sparking. Then check that all the components are correctly attached.
3. The PWS 1100 angle grinder is fitted with a specially designed switch ① for increased safety.

TO SWITCH ON: slide the ON/OFF switch ① forwards

TO SWITCH OFF: gently press the ON/OFF switch ① backwards

Warning: Only use the spindle lock when the electric motor has come to a standstill.

SETTING THE SPEED

You can set the required speed / rpm using the speed control wheel ② to suit your work.

You can also change the speed whilst you are working. A practical test before you start can help you to determine the most appropriate speed to use.

To **increase** the speed (rotation), turn the speed control wheel ② towards **6** (6 = highest speed).

To **decrease** the speed (rotation), turn the speed control wheel ② towards **1** (1 = lowest speed).

CHANGING THE GRINDING DISC

⚠ Note: Only use discs that are free of contaminants, as indicated in "Important safety advice".

Isolate the tool from the electrical power supply by pulling the plug from the socket.

Press the spindle lock ④ to block the drive. Remove the clamping nut ⑦ using the wrench.

Once the grinding disc has been changed retighten the clamping nut ⑦.

Warning: If after replacement, the grinding disc runs erratically or vibrates, it must be changed immediately.

AUXILIARY HANDLE

⚠ Warning: For your safety, only use the grinder with the auxiliary handle ③ fitted.

The auxiliary handle ③ can be fitted to the left or right hand side of the grinding head to suit your way of working.

MAINTENANCE OF THE ANGLE GRINDER

1. Clean the angle grinder regularly. For the best results do this straight after the work has been completed.
2. Do not allow liquids to get inside the grinder. Use a soft cloth for cleaning the housing. Do not use petrol, solvents or cleaners that might attack the plastic.
3. Air vents must always be clear and clean.
4. The replacement carbon brushes supplied may only be changed and fitted at an authorised repair centre (both brushes must be changed at the same time).

ADVICE ON WORKING METHODS, TIPS AND TRICKS

- If the weight of the workpiece is insufficient to keep it absolutely still during grinding, then fasten it securely.
- Do not press on with the grinder so much that you bring it to a standstill.
- For the best grinding performance move the grinder evenly backwards and forwards over the workpiece at an angle of 15° to 30° (angle between the grinding disc and workpiece).
- When working on inclined surfaces, do not press the grinder on to the workpiece with too much force. If the speed drastically reduces, do not press on as hard and that will ensure you work safely and effectively. If the grinder is brought to a sudden halt or jams, switch off the power immediately.
- Only use cutting and grinding discs that have been MPA certified. Never use cutting discs for roughing.
- Cutting: Work with moderate force and do not use the cutting disc' at an angle. For profiled sections and rectangular hollow sections you will find it best to cut where the cross section is the smallest.

- * For polishing plastics use a felt polishing disc¹. For polishing metals use a buffing disc¹. Select a slow speed — turn the speed control wheel ② to setting **1**.
 - * For removing paint from metal use an appropriate abrasive disc¹. Select a slow to medium speed — turn the speed control wheel ② to setting **2-3**.
 - * For grinding metal and stone use an appropriate grinding disc¹. Select a medium to high speed — turn the speed control wheel ② to setting **4-6**.
 - * For rough grinding metals use an appropriate roughing disc¹. Select a high speed — turn the speed control wheel ② to setting **6**.
- * = These are advisory recommendations only. Before you start work, you should carry out a test to see which speed is most suitable for your work.
¹ = These accessories are not supplied with the angle grinder.

Further practical tips for power tools can be found in the accompanying booklet on safety advice.

We reserve the right to make technical modifications in the course of further development.

STATEMENT OF CONFORMITY

We, Kompernaß Handelsgesellschaft mbH, Burgstr. 21, D-44867 Bochum, hereby declare that this product conforms with the following EC regulations:

EC low voltage regulations:	(98/37 EEC)
Electromagnetic compatibility:	(73/23/EEC), (93/68 EEC)
Applicable harmonised standards:	(89/336 EEC), EN 50144-1:1998; DIN VDE 0740 Teil 21:1994 EN 55014-1:1993 +A1 +A2; EN 61000-3-2:1995 +A1 +A2; EN 61000-3-3:1995 EN 55014-2:1997

Manufacturer:	PARKSIDE
Model type:	PWS 1100
Description:	ANGLE GRINDER

Bochum, 30.09.2002



Hans Kompernaß
- Managing Director -

PARKSIDE

WARRANTY

This piece of equipment is covered by a **36-month warranty as of the date of purchase**. The equipment was produced with the greatest of care and underwent thorough testing before delivery. In the unlikely event of detecting a functional defect, please return the equipment in its original packaging with the proof of purchase (if available) to the closest service address.

Damage caused due to improper handling as well as regular wear of the parts are not covered by this warranty.

Beaver Electronic Services · The Lodge, Premier Business Park

Long Street, Walsall · West Midlands, WS2 9DY

Tel.: 0 19 22/72 55 54 · Fax: 0 19 22/72 54 17

WARRANTY

This piece of equipment is covered by a **36-month warranty as of the date of purchase**. The equipment was produced with the greatest of care and underwent thorough testing before delivery. In the unlikely event of detecting a functional defect, please return the equipment in its original packaging with the proof of purchase (if available) to the closest service address.

Damage caused due to improper handling as well as regular wear of the parts are not covered by this warranty.

Irish Web Specialists

1 Verbena Avenue · Dublin 13

Tel.: 01/8 32 04 92 · Fax: 01/8 39 68 29

PARKSIDE

